

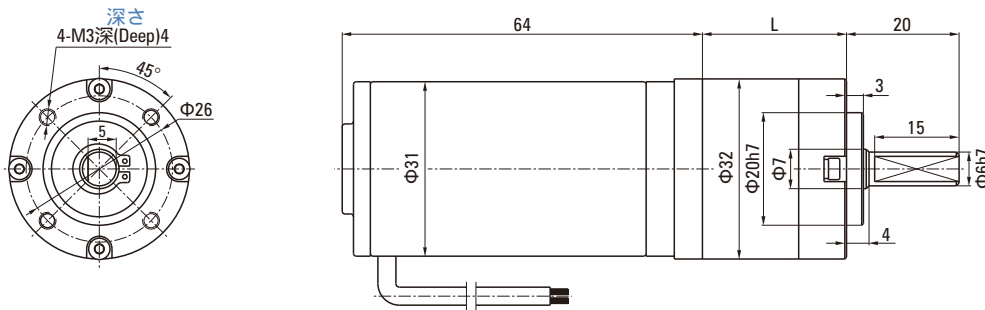

外径32ブラシ付遊星減速モーターの外観図

■ 外径32直流有刷行星減速电机外形图 Outside Diameter 32 DC Brush Motor



モーター型番 Motor Type	減速機型番 Gearbox Model	減速比 Gear Ratio	L寸法 Dimension
Z32DPN	一段 一级Stage1	3.7~6.75	25.6
	二段 二级Stage2	14~46	35.9
	三段 三级Stage3	51~308	46.2

モーター配線図

电机接线图 Wiring Diagram

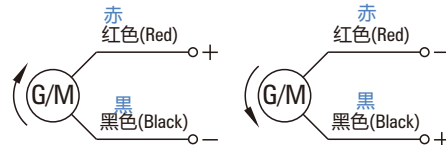

ブラシ付DCモーターの技術データ

■ 有刷直流电机技术参数 Blush DC Motor Technical Data

电机型号モーター型番 Motor Type	電圧 Voltage	出力 Power	無負荷電流 No-load Current	無負荷回転数 No-load Speed	定格電流 Rated Current	定格回転数 Rated Speed	定格トルク Rated Torque	モーター寿命 Motor Life
	V	W	A	RPM	A	RPM	N.m	H
Z32DPN2410-40S	24	10	0.4	5000	0.7	4000	0.024	2000
Z32DPN2415-50S	24	15	0.5	6000	1.1	5000	0.029	2000

ブラシ付遊星減速モーターの技術データ

■ 有刷直流行星減速电机技术参数 Blush DC Planetary Gear Motor Technical Data-Z32DPN2410-40S

減速比 Ratio 減速比	3.7	4.29	5.18	6.75	13.73	19.2	25	28.93	34.97	45.56	50.89	68.08	78.7
輸出軸转速 r/min 出力軸回転数 Output shaft speed	1081	932	772	592	285	210	160	137	114	87	78	59	50
允許力矩 N.m 許容トルク Allowable torque	0.080	0.092	0.111	0.145	0.270	0.367	0.483	0.561	0.6777	0.890	0.889	1.185	1.3777
減速級数 減速段数 Reduction stage	1	1	1	1	2	2	2	2	2	2	3	3	3
減速比 Ratio 減速比	92.7	99.5	115.1	129.6	149.9	168.85	195.28	236.1	307.54				
輸出軸转速 r/min 出力軸回転数 Output shaft speed	43	40	35	31	26	23	20	17	13				
允許力矩 N.m 許容トルク Allowable torque	1.621	1.743	2.004	2.266	2.614	2.945	3.400	4.000	4.000				
減速級数 減速段数 Reduction stage	3	3	3	3	3	3	3	3	3				

■ ZPNΦ32

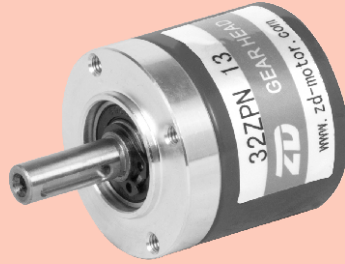

外径32遊星減速機

■ 外径32行星減速器 Outdiameter 32mm Planetary Gearbox

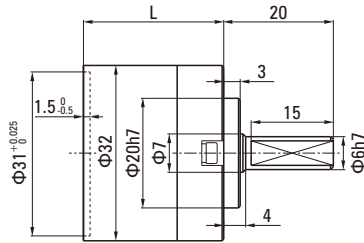
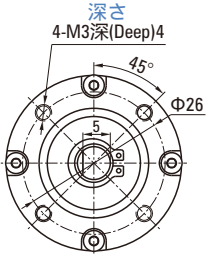

減速機型番 Gearbox Model	減速比 Gear Ratio	L寸法 L尺寸(mm) Dimension
一段 32ZPN□二段	一级Stage1 3.7~6.75	25.6
	二级Stage2 14~46	35.9
三段	三级Stage3 51~308	46.2

传动级数 伝動段数 Transmission Stage	一级 一段 Stage 1	二级 二段 Stage 2	三级 三段 Stage 3
传动效率 Transmission efficiency 伝動効率	90%	81%	73%
最大径向负载 Max radial load 最大ラジアル荷重	140N	140N	140N
最大轴向负载 Max axial load 最大スラスト荷重	50N	50N	50N
额定扭矩 Rated torque 定格トルク	1N.m	2.25N.m	4N.m
瞬间承受扭矩 Instant beared torque 瞬間許容トルク	2倍与额定扭矩 Two times of the rated torque 定格トルクの2倍		
工作温度 Operating temperature 動作温度	-10°C ~ +80°C		
润滑方式 Lubrication type 潤滑方式	终生润滑 终生潤滑 Lifetime lubrication		
安装方式 Mounting type 取付方式	任意取付 任意安装 Any		
推荐输入转速 Recommend input speed 推薦入力回転数	≤3000RPM		
输入与输出转向 Input and output direction 入力と出力の回転方向	同じ 相同 Same direction		
噪音 Noise 騒音	< 60dB(A) (L=1m, 3000rpm)		

モーターの組み合わせ提案 电机配合方案 Motor Matching Scheme

一段減速比 二段減速比 三段減速比

Da	一级速比 One stage of gear ratio	二级速比 Second stage of gear ratio	三级速比 Third stage of gear ratio
Φ8.02 ^{-0.05} / _{-0.08}	3.7	13.73	50.89
Φ7.05 ^{-0.05} / _{-0.08}	4.29	-	68.08
	-	-	78.7
Φ5.82 ^{-0.05} / _{-0.08}	5.18	19.2	99.5
	-	-	115.1
Φ4.57 ^{-0.05} / _{-0.08}	6.75	25	92.7
		28.93	129.6
		34.97	149.9
		45.56	-

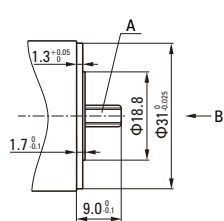
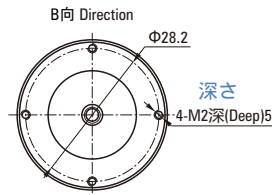

15は歯切りカッターの逃し量、8.5は歯切りの有効長さ

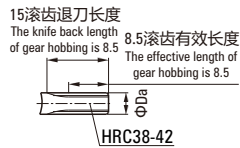

ZPNシリーズ

ZPN系列
ZPN SERIES

ブラシ付
BRUSH有刷

■ ZPNΦ42



外径42ブラシ付遊星減速モーターの外観図

■ 外径42直流有刷行星減速电机外形图紙 Outside Diameter 42 DC Brush Motor

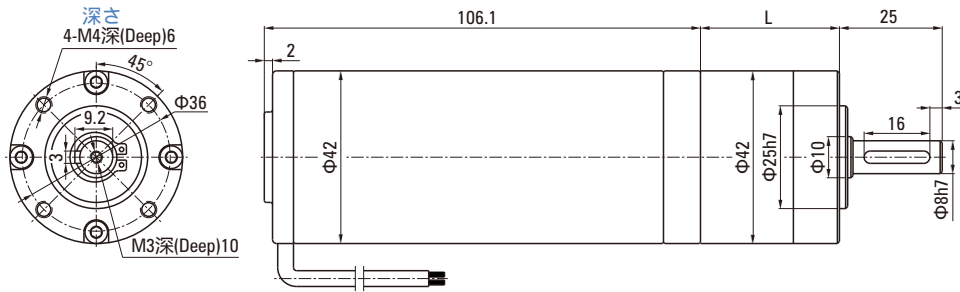

モーター型番 Motor Type	減速機型番 Gearbox Model	減速比 Gear Ratio	L寸法 L Dimension (mm)
Z42DPN	42PN□	3.65~8.63	33.8
		13.53~58.22	47.4
		67.08~392.98	61.0

モーター配線図
电机接线图 Wiring Diagram

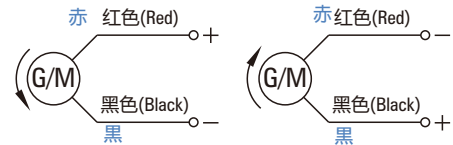

ブラシ付DCモーターの技術データ

■ 有刷直流电机技术参数 Blush DC Motor Technical Data

电机型号 Motor Type	電圧 Voltage	出力 Rated Power	無負荷電流 No-load Current	無負荷回転数 No-load Speed	定格電流 Rated Current	定格回転数 Rated Speed	定格トルク Rated Torque	モーター寿命 Motor Life
モーター型番	V	W	A	RPM	A	RPM	N.m	H
Z42DPN2425-30S	24	25	0.6	3500	1.6	3000	0.080	600

ブラシ付遊星減速モーターの技術データ

■ 有刷直流行星減速电机技术参数 Blush DC Planetary Gear Motor Technical Data-Z42DPN2425-30S

減速比 Ratio 減速比	3.65	5.36	6.55	8.63	13.53	18.92	24.65	28.05	33.92	44.69	58.22	67.08	81.11
輸出軸转速 r/min 出力軸回転数	822	560	458	348	222	159	122	107	89	67	52	45	37
允許力矩 N.m 許容トルク	0.26	0.39	0.47	0.62	0.88	1.23	1.60	1.82	2.20	2.90	3.77	2.75	4.74
減速級数 減速段数	1	1	1	1	2	2	2	2	2	2	2	3	3

減速比 Ratio 減速比	91.36	102.88	118.98	127.74	145.36	165.64	191.56	231.61	301.68	392.98			
輸出軸转速 r/min 出力軸回転数	33	29	25	24	21	18	16	13	9.9	7.6			
允許力矩 N.m 許容トルク	5.34	6.01	6.95	7.46	8.49	9.67	11.19	13.53	15.00	15.00			
減速級数 減速段数	3	3	3	3	3	3	3	3	3	3			

ZPNシリーズ

ZPN系列 ZPN SERIES

■ ZPNΦ42

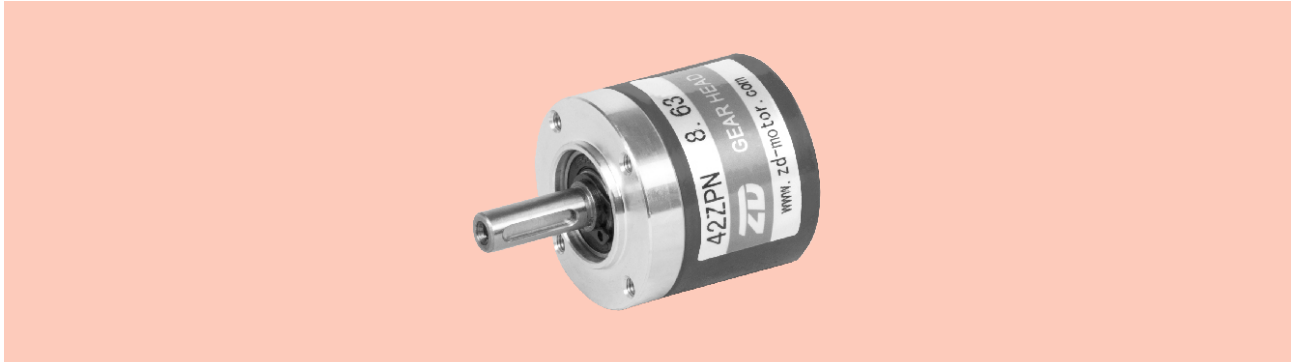

外径42遊星減速機

■ 外径42行星減速器 Outdiameter 42mm Planetary Gearbox

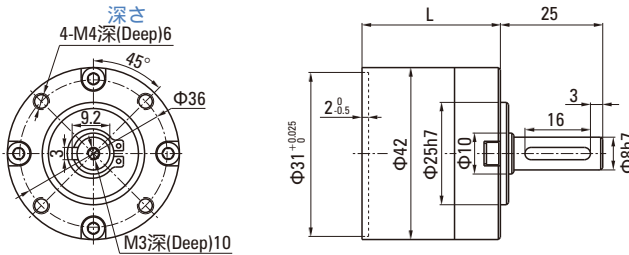

減速機型番 Gearbox Model	減速比 Gear Ratio	L寸法 L尺寸(mm) Dimension
一段 一级Stage1	3.65~8.63	33.8
42ZPN□ 二段 二级Stage2	14~58	47.4
三段 三级Stage3	67~393	61.0

传动级数 伝動段数 Transmission Stage	一级 一段 Stage 1	二级 二段 Stage 2	三级 三段 Stage 3
传动效率 Transmission efficiency	90%	81%	73%
最大ラジアル荷重 最大径向负载 Max radial load	300N	300N	300N
最大スラスト荷重 最大轴向负载 Max axial load	110N	110N	110N
定格トルク 额定扭矩 Rated torque	3N.m	7.5N.m	15N.m
瞬間許容トルク 瞬间承受扭矩 Instant beared torque	定格トルクの二倍 2倍与额定扭矩 Two times of the rated torque		
工作温度 Operating temperature 動作温度	-10°C ~ +80°C		
潤滑方式 Lubrication type 潤滑方式	終生潤滑 终生润滑 Lifetime lubrication		
安裝方式 Mounting type 取付方式	任意安裝 Any 任意取付		
推荐输入转速 Recommend input speed 推荐入力回転数	≤3000RPM		
输入与输出转向 Input and output direction 入力と出力の回転方向	相同 Same direction 同じ		
噪音 Noise 騒音	< 60dB(A) (L=1m, 3000rpm)		

モーターの組み合わせ提案 电机配合方案 Motor Matching Scheme

Da	一段減速比 二段減速比 三段減速比			
	一级速比 One stage of gear ratio	二级速比 Second stage of gear ratio	三级速比 Third stage of gear ratio	
Φ7.12 ^{-0.05/-0.08}	5.36	-	102.88	
Φ5.78 ^{-0.05/-0.08}	6.55	28.05	145.36	
		33.92	-	
Φ4.56 ^{-0.05/-0.08}	8.63	44.69	165.64	
		58.22	191.56	
		-	231.61	
		-	301.68	
Φ10.73 ^{-0.05/-0.08}	3.65	-	392.98	
		-	13.53	67.08
		-	18.92	81.11
		-	24.65	91.36
-	-	-	127.74	

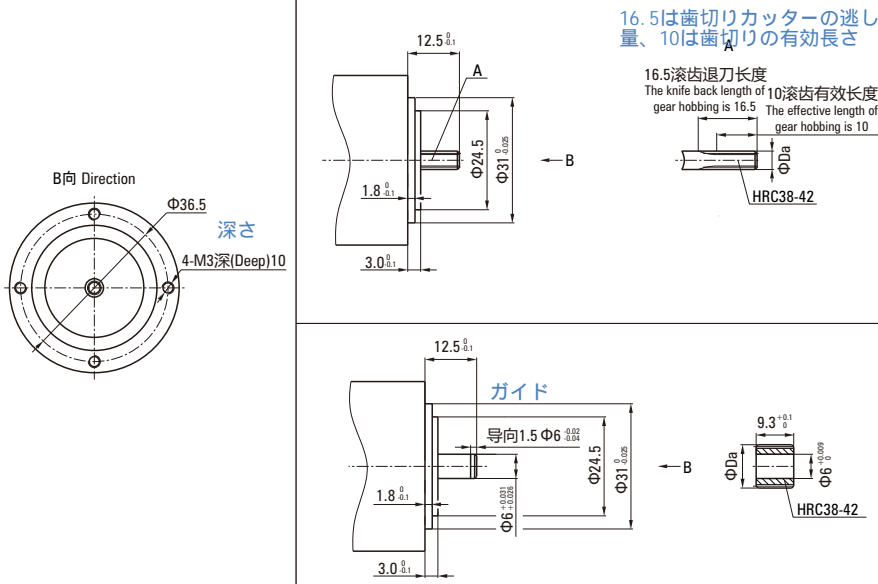

■ ZPNΦ52 ブラシ付
BRUSH有刷

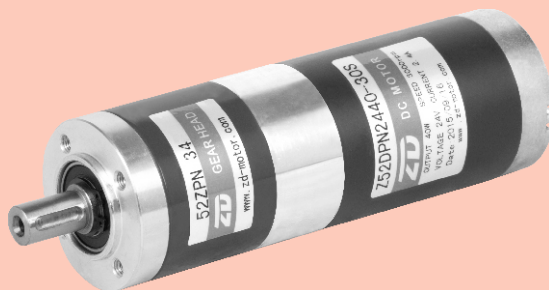

外径52ブラシ付遊星減速モーターの外観図

■ 外径52直流有刷行星減速电机外形图紙 Outside Diameter 52 DC Brush Motor

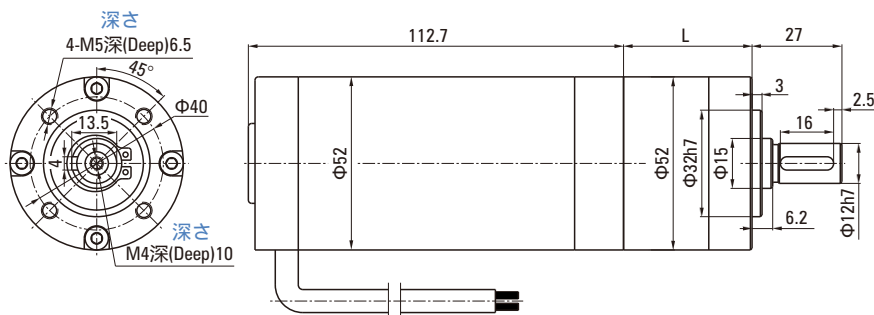

モーター配線図
电机接线图 Wiring Diagram

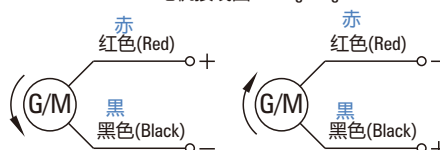

モーター型番 Motor Type	減速機型番 Gearbox Model	減速比 Gear Ratio	L寸法 L尺寸(mm) Dimension
Z52DPN	52PN□	3.65~8.63	38.6
		13.53~58.22	54.2
		67.08~392.98	69.8

ブラシ付DCモーターの技術データ

■ 有刷直流电机技术参数 BLDC Motor Technical Data

モーター型番 Motor Type	電圧 Voltage	定格出力 Rated Power	無負荷電流 No-load Current	無負荷回転数 No-load Speed	定格電流 Rated Current	定格回転数 Rated Speed	定格トルク Rated Torque	モーター寿命 Motor Life
	V	W	A	RPM	A	RPM	N.m	H
Z52DPN2440-30S	24	40	1.0	3500	2.5	3000	0.127	2000
Z52DPN2460-30S	24	60	1.2	3600	4.0	3000	0.191	2000

ブラシ付遊星減速モーターの技術データ

■ 有刷直流行星減速电机技术参数 Blush DC Planetary Gear Motor Technical Data-Z52DPN2440-30S

減速比 Ratio 減速比	3.65	5.36	6.55	8.63	13.53	18.92	24.65	28.05	33.92	44.69	58.22	67.08	81.11
輸出軸回転数 r/min 出力軸回転数 Output shaft speed	322	560	458	348	222	159	122	107	89	67	52	45	37
允許力矩 N.m 許容トルク Allowable torque	0.42	0.61	0.75	0.99	1.39	1.95	2.54	2.89	3.49	4.60	5.99	6.22	7.52
減速級数 減速段数 Reduction stage	1	1	1	1	2	2	2	2	2	2	2	3	3
減速比 Ratio 減速比	91.36	102.88	118.98	127.74	145.36	165.64	191.56	231.61	301.68	392.98			
輸出軸回転数 r/min 出力軸回転数 Output shaft speed	33	29	25	24	21	18	16	13	9.9	7.6			
允許力矩 N.m 許容トルク Allowable torque	8.47	9.54	11.03	11.84	13.48	15.36	17.76	21.47	25.00	25.00			
減速級数 減速段数 Reduction stage	3	3	3	3	3	3	3	3	3	3			

■ ZPNΦ52

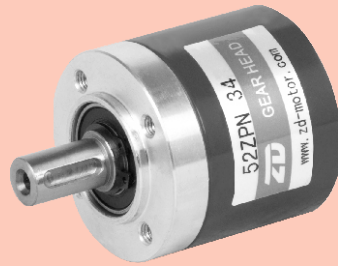

外径52遊星減速機

■ 外径52行星減速器 Outdiameter 52mm Planetary Gearbox

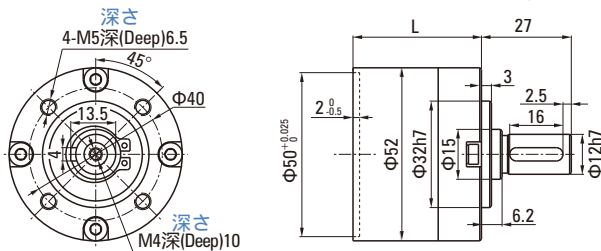

減速機型番 Gearbox Model	減速比 Gear Ratio	L寸法 L尺寸(mm) Dimension
52ZPN□	一段 一级 Stage1	3.65~8.63
	二段 二级 Stage2	14~58
	三段 三级 Stage3	67~393

传动级数 传动段数 Transmission Stage	一级 一段 Stage 1	二级 二段 Stage 2	三级 三段 Stage 3
传动效率 Transmission efficiency 传动效率	90%	81%	73%
最大径向负载 Max radial load 最大ラジアル荷重	450N	450N	450N
最大轴向负载 Max axial load 最大スラスト荷重	150N	150N	150N
额定扭矩 Rated torque 定格トルク	4N.m	12N.m	25N.m
瞬间承受扭矩 Instant beared torque 瞬間許容トルク	2倍与额定扭矩 Two times of the rated torque 定格トルクの二倍		
工作温度 Operating temperature 動作温度	-10°C ~ +80°C		
润滑方式 Lubrication type 潤滑方式	终生润滑 Lifetime lubrication 终生潤滑		
安装方式 Mounting type 取付方式	任意安装 Any 任意取付		
推荐输入转速 Recommend input speed 推薦入力回転数	≤3000RPM		
输入与输出转向 Input and output direction 入力と出力の回転方向	同じ 相同 Same direction		
噪音 Noise 騒音	< 60dB(A) (L=1m, 3000rpm)		

モーターの組み合わせ提案 电机配合方案 Motor Matching Scheme

Da	一段減速比 二段減速比 三段減速比		
	一级速比 One stage of gear ratio	二级速比 Second stage of gear ratio	三级速比 Third stage of gear ratio
Φ8.88 ^{-0.05} / _{-0.08}	5.36	-	102.88
Φ7.23 ^{-0.05} / _{-0.08}	6.55	28.05	145.36
Φ5.73 ^{-0.05} / _{-0.08}	8.63	44.69	165.64
		58.22	191.56
		-	231.61
		-	301.68
Φ13.42 ^{-0.05} / _{-0.08}	3.65	13.53	67.08
		18.92	81.11
		24.65	91.36
		-	127.74

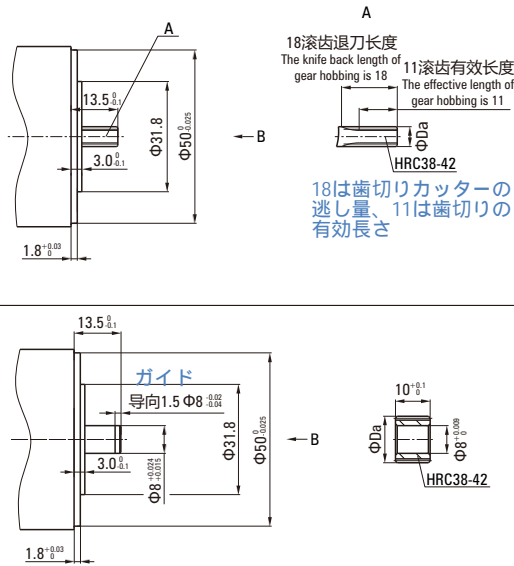
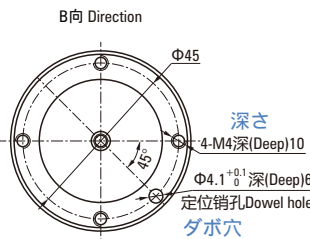

ZPNシリーズ
ZPN系列
ZPN SERIES

■ ZPNΦ62 BRUSH有刷

ブラシ付



外径62ブラシ付遊星減速モーターの外観図

■ 外径62直流有刷行星減速电机外形图纸 Outside Diameter 62 DC Brush Motor

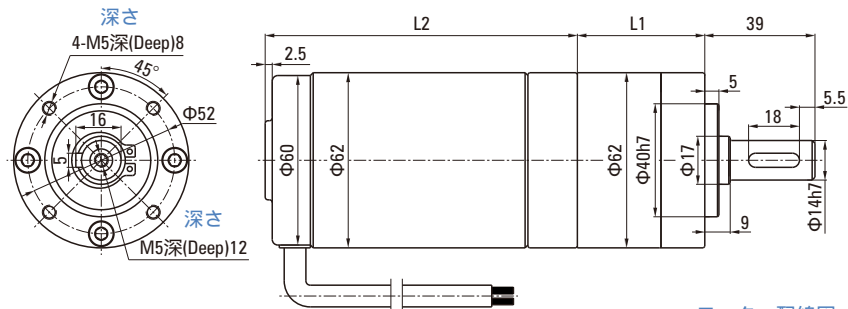

モーター型番 Motor Type	減速機型番 Gearbox Model	減速比 Gear Ratio	L寸法 Dimension
Z62DPN	62PN□	3.65~8.63	45.1
		13.53~58.22	62.7
		67.08~392.98	80.3

モーター配線図
电机接线图 Wiring Diagram

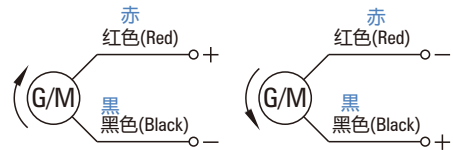

ブラシ付DCモーターの技術データ

■ 有刷直流电机技术参数 Blush DC Motor Technical Data

モーター型番 Motor Type	電圧 Voltage	定格出力 Rated Power	無負荷電流 No-load Current	無負荷回転数 No-load Speed	定格電流 Rated Current	定格回転数 Rated Speed	定格トルク Rated Torque	モーター寿命 Motor Life	L2寸法 Dimension
	V	W	A	RPM	A	RPM	N.m	H	mm
Z62DPN2440-30S	24	40	1.2	3500	2.5	3000	0.127	2000	110.5
Z62DPN2460-30S	24	60	1.2	3500	3.5	3000	0.191	2000	121.5
Z62DPN2490-30S	24	90	1.5	3700	5.5	3000	0.287	2000	133.5

ブラシレス遊星減速モーターの技術データ

■ 有刷直流行星減速电机技术参数 Blush DC Planetary Gear Motor Technical Data-Z62DPN2460-30S

減速比 Ratio 減速比	3.65	5.36	6.55	8.63	13.53	18.92	24.65	28.05	33.92	44.69	58.22	67.08	81.11
輸出軸转速 r/min Output shaft speed	22	560	458	348	222	159	122	107	89	67	52	45	37
允許力矩 N.m Allowable torque	0.63	0.92	1.13	1.48	2.09	2.93	3.81	4.34	5.25	6.91	9.01	9.35	11.31
減速級数 Reduction stage	1	1	1	1	2	2	2	2	2	2	2	3	3
減速比 Ratio 減速比	91.36	102.88	118.98	127.74	145.36	165.64	191.56	231.61	301.68	392.98			
輸出軸转速 r/min Output shaft speed	33	29	25	24	21	18	16	13	9.9	7.6			
允許力矩 N.m Allowable torque	12.74	14.34	16.58	17.81	20.27	23.10	26.71	32.29	42.06	50.00			
減速級数 Reduction stage	3	3	3	3	3	3	3	3	3	3			

ZPNシリーズ

ZPN系列 ZPN SERIES

■ ZPNΦ62

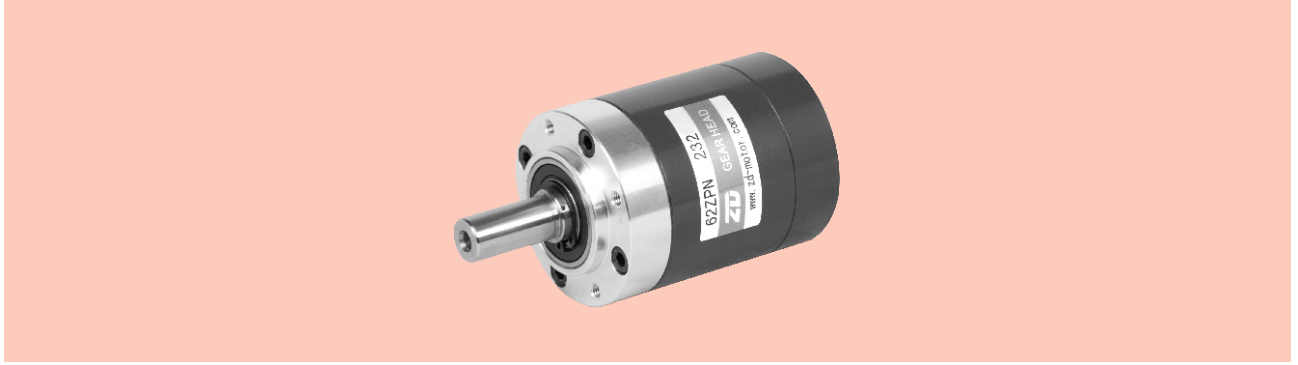

外径62遊星減速機

■ 外径62行星減速器 Outdiameter 62mm Planetary Gearbox

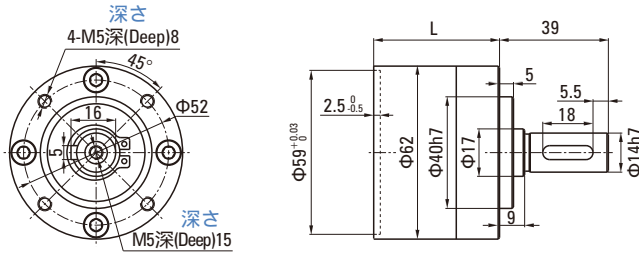

減速機型番 Gearbox Model	減速比 Gear Ratio	L寸法 L尺寸(mm) Dimension
一段 62ZPN□	一级Stage1 3.65~8.63	45.1
二段	二级Stage2 14~58	62.7
三段	三级Stage3 67~393	80.3

传动级数 伝動段数 Transmission Stage	一级 一段 Stage 1	二级 二段 Stage 2	三级 三段 Stage 3
传动效率 Transmission efficiency 伝動効率	90%	81%	73%
最大径向负载 Max radial load 最大ラジアル荷重	520N	520N	520N
最大轴向负载 Max axial load 最大スラスト荷重	150N	150N	150N
额定扭矩 Rated torque 定格トルク	8N.m	25N.m	50N.m
瞬间承受扭矩 Instant beared torque 瞬間許容トルク	2倍与额定扭矩 Two times of the rated torque 定格トルクの二倍		
工作温度 Operating temperature 動作温度	-10°C ~ +80°C		
润滑方式 Lubrication type 潤滑方式	终生潤滑 终生潤滑 Lifetime lubrication		
安装方式 Mounting type 取付方式	任意取付 任意安装 Any		
推荐输入转速 Recommend input speed 推薦入力回転数	≤3000RPM		
输入与输出转向 Input and output direction 入力と出力の回転方向	同じ 相同 Same direction		
噪音 Noise 騒音	< 60dB(A) (L=1m, 3000rpm)		

モーターの組み合わせ提案 电机配合方案 Motor Matching Scheme

Da	一段減速比 二段減速比 三段減速比		
	一级速比 One stage of gear ratio	二级速比 Second stage of gear ratio	三级速比 Third stage of gear ratio
Φ10.66 ^{+0.05} / _{-0.08}	5.36	-	102.88
Φ8.69 ^{-0.05} / _{-0.08}	6.55	28.05	145.36
		33.92	-
Φ6.82 ^{-0.05} / _{-0.08}	8.63	44.69	165.64
		58.22	191.56
		-	231.61
		-	301.68
Φ16.11 ^{-0.05} / _{-0.08}	3.65	-	392.98
		13.53	67.08
		18.92	81.11
		24.65	91.36
-	-	-	127.74

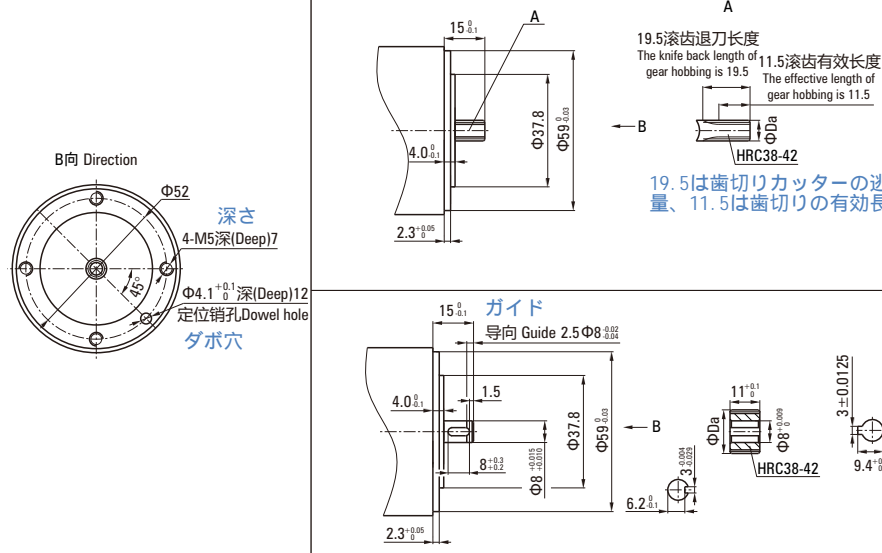

ZPNシリーズ
ZPN系列
ZPN SERIES

■ ZPNΦ72
ブラシ付
BRUSH有刷

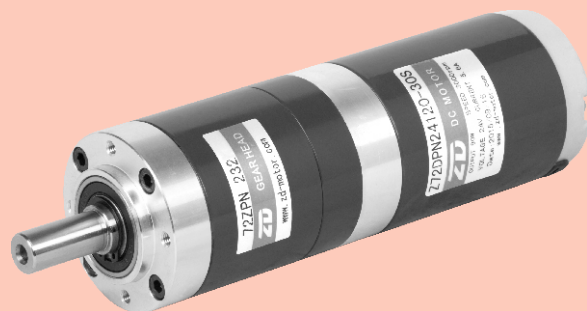

外径72ブラシ付遊星減速モーターの外観図

■ 外径72直流有刷行星減速电机外形图纸 Outside Diameter 72 DC Brush Motor

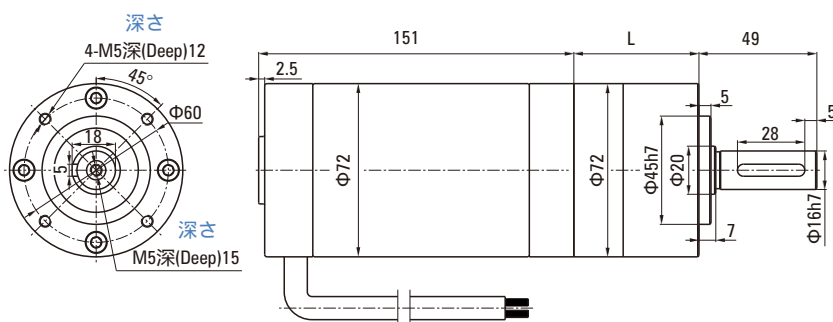

モーター型番 Motor Type	減速機型番 Gearbox Model	減速比 Gear Ratio	L寸法 L尺寸(mm) Dimension
Z72DPN	72PN□	3.65~8.63	52.00
		13.53~58.22	72.15
		67.08~392.98	92.30

モーター配線図

电机接线图 Wiring Diagram

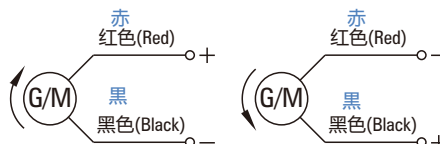

ブラシ付DCモーターの技術データ

■ 有刷直流电机技术参数 Blush DC Motor Technical Data

モーター型番 Motor Type	電圧 Voltage	定格出力 Rated Power	無負荷電流 No-load Current	無負荷回転数 No-load Speed	定格電流 Rated Current	定格回転数 Rated Speed	定格トルク Rated Torque	モーター寿命 Motor Life
	V	W	A	RPM	A	RPM	N.m	H
Z72DPN1260-30S	12	60	2.0	3500	7.2	3000	0.191	2000
Z72DPN2490-30S	24	90	2.0	3400	5.5	3000	0.287	2000
Z72DPN24120-30S	24	120	2.0	3500	7.2	3000	0.382	2000

ブラシ付遊星減速モーターの技術データ

■ 有刷直流行星減速电机技术参数 Blush DC Planetary Gear Motor Technical Data-Z72DPN2490-30S

減速比 Ratio 減速比	3.65	5.36	6.55	8.63	13.53	18.92	24.65	28.05	33.92	44.69	58.22	67.08	81.11
輸出軸转速 r/min Output shaft speed	22	560	458	348	222	159	122	107	89	67	52	45	37
允許力矩 N.m Allowable torque	0.94	1.38	1.69	2.23	3.15	4.40	5.73	6.52	7.89	10.39	13.53	14.05	16.99
減速級数 Reduction stage	1	1	1	1	2	2	2	2	2	2	2	3	3
減速比 Ratio 減速比	91.36	102.88	118.98	127.74	145.36	165.64	191.56	231.61	301.68	392.98			
輸出軸转速 r/min Output shaft speed	3	29	25	24	21	18	16	13	9.9	7.6			
允許力矩 N.m Allowable torque	19.14	21.55	24.93	26.76	30.45	34.70	40.13	48.52	63.20	82.33			
減速級数 Reduction stage	3	3	3	3	3	3	3	3	3	3			

■ ZPNΦ72



外径32遊星減速機

■ 外径72行星減速器 Outdiameter 72mm Planetary Gearbox

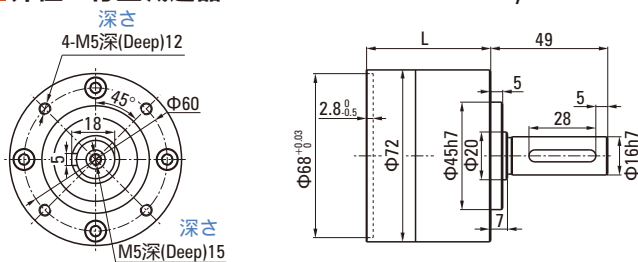

減速機型番 減速比 L寸法

減速機型番 Gearbox Model	減速比 Gear Ratio	L寸法 Dimension
一段 72ZPN□二段	一级Stage1 3.65~8.63	52.00
	二级Stage2 14~58	72.15
	三级Stage3 67~393	92.30

传动级数 传动段数 Transmission Stage	一级 一段 Stage 1	二级 二段 Stage 2	三级 三段 Stage 3
传动效率 传动效率 Transmission efficiency	90%	81%	73%
最大ラジアル荷重 最大径向负载 Max radial load	760N	760N	760N
最大スラスト荷重 最大轴向负载 Max axial load	160N	160N	160N
定格トルク 额定扭矩 Rated torque	14N.m	42N.m	84N.m
瞬間許容トルク 瞬间承受扭矩 Instant beared torque	定格トルクの二倍 2倍与额定扭矩 Two times of the rated torque		
動作温度 工作温度 Operating temperature	-10°C ~ +80°C		
潤滑方式 润滑方式 Lubrication type	终生潤滑 终生润滑 Lifetime lubrication		
取付方式 安装方式 Mounting type	任意取付 任意安装 Any		
推薦入力回転数 推荐输入转速 Recommend input speed	≤3000RPM		
入力と出力の回転方向 转向 Input and output direction	同じ 相同 Same direction		
騒音 噪音 Noise	< 60dB(A) (L=1m, 3000rpm)		

モーターの組み合わせ提案 电机配合方案 Motor Matching Scheme

Da	一段減速比 二段減速比 三段減速比		
	一级速比 One stage of gear ratio	二级速比 Second stage of gear ratio	三级速比 Third stage of gear ratio
Φ12.47 ^{+0.05} _{-0.08}	5.36	-	102.88
Φ10.27 ^{+0.05} _{-0.08}	6.55	28.05	145.36
Φ7.99 ^{+0.05} _{-0.08}	8.63	44.69	165.64
		58.22	191.56
		-	231.61
		-	301.68
Φ18.68 ^{+0.05} _{-0.08}	3.65	-	392.98
		13.53	67.08
		18.92	81.11
		24.65	91.36
		-	127.74

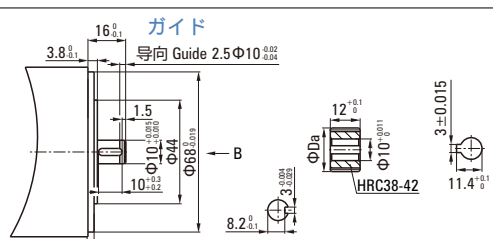
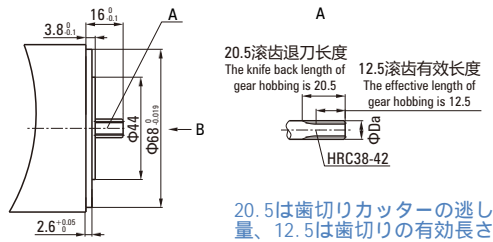
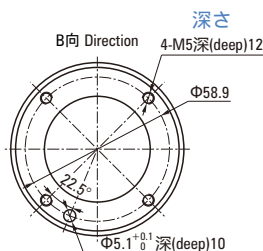

■ ZPNΦ82 BRUSH有刷

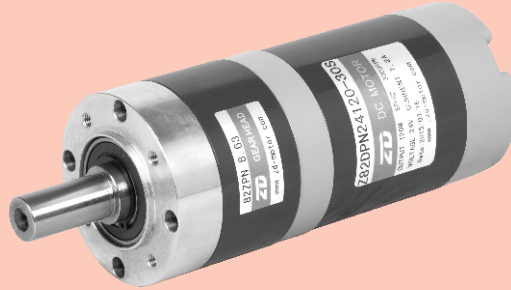

■ 外径82直流有刷行星减速电机外形图纸 Outside Diameter 82 DC Brush Motor

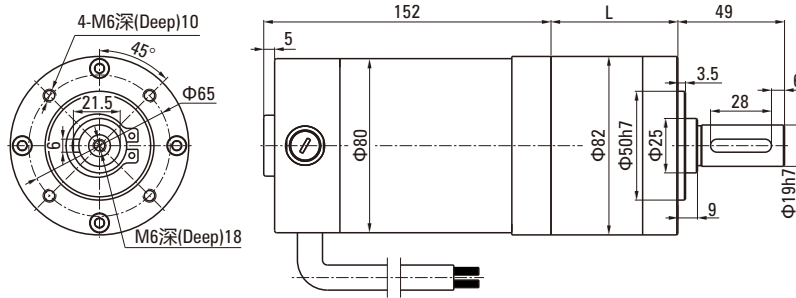

电机型号 Motor Type	减速箱型号 Gearbox Model	减速比 Gear Ratio	L尺寸(mm) Dimension
Z82DPN	82PN□	3.65~8.63	63.70
		13.53~58.22	80.50
		67.08~392.98	103.2

电机接线图 Wiring Diagram

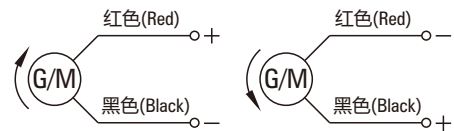

■ 有刷直流电机技术参数 Blush DC Motor Technical Data

电机型号 Motor Type	电压 Voltage V	额定功率 Rated Power W	空载电流 No-load Current A	空载转速 No-load Speed RPM	额定电流 Rated Current A	额定转速 Rated Speed RPM	额定力矩 Rated Torque N.m	电机寿命 Motor Life H
Z82DPN1290-30S	12	90	2.5	3500	10.5	3000	0.287	2000
Z82DPN24120-30S	24	120	2.0	3400	7.20	3000	0.382	2000
Z82DPN48180-30S	48	180	1.5	3400	5.50	3000	0.573	2000

■ 有刷直流行星减速电机技术参数 Blush DC Planetary Gear Motor Technical Data-Z82DPN24120-30S

减速比 Ratio	3.65	5.36	6.55	8.63	13.53	18.92	24.65	28.05	33.92	44.69	58.22	67.08	81.11
输出轴转速 r/min Output shaft speed	822	560	458	348	222	159	122	107	89	67	52	45	37
允许力矩 N.m Allowable torque	1.30	1.80	2.30	3.00	4.20	5.90	7.60	8.70	10.5	13.8	18.0	18.7	22.6
减速级数 Reduction stage	1	1	1	1	2	2	2	2	2	2	2	3	3

减速比 Ratio	91.36	102.88	118.98	127.74	145.36	165.64	191.56	231.61	301.68	392.98			
输出轴转速 r/min Output shaft speed	33	29	25	24	21	18	16	13	9.9	7.6			
允许力矩 N.m Allowable torque	25.5	28.7	33.2	35.6	40.5	46.2	53.4	64.6	84.0	84.0			
减速级数 Reduction stage	3	3	3	3	3	3	3	3	3	3			

ZPN系列 ZPN SERIES

■ ZPNΦ82

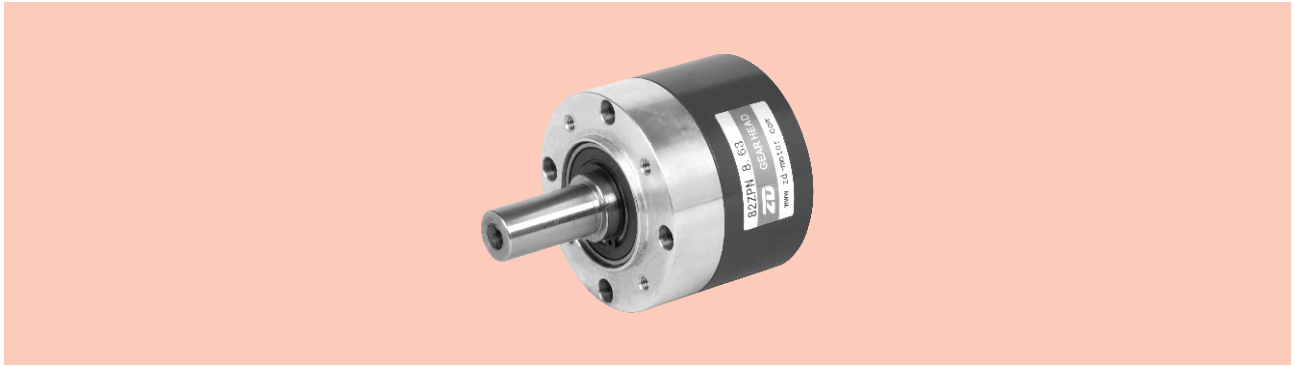

■ 外径82行星减速器 Outdiameter 82mm Planetary Gearbox

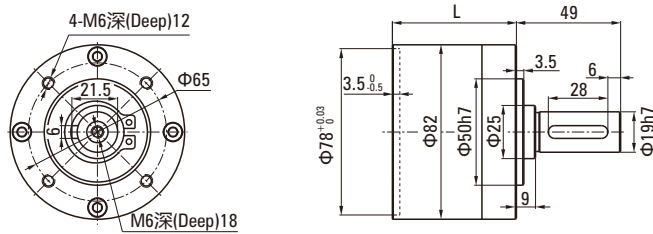

减速箱型号 Gearbox Model	减速比 Gear Ratio	L尺寸(mm) Dimension
82ZPN□	一级Stage1	3.65~8.63
	二级Stage2	14~58
	三级Stage3	67~393

传动级数 Transmission Stage	一级 Stage 1	二级 Stage 2	三级 Stage 3
传动效率 Transmission efficiency	90%	81%	73%
最大径向负载 Max radial load	1000N	1000N	1000N
最大轴向负载 Max axial load	200N	200N	200N
额定扭矩 Rated torque	20N.m	60N.m	120N.m
瞬间承受扭矩 Instant beared torque	2倍与额定扭矩 Two times of the rated torque		
工作温度 Operating temperature	-10°C ~ +80°C		
润滑方式 Lubrication type	终生润滑 Lifetime lubrication		
安装方式 Mounting type	任意安装 Any		
推荐输入转速 Recommend input speed	≤3000RPM		
输入与输出转向 Input and output direction	相同 Same direction		
噪音 Noise	< 60dB(A) (L=1m, 3000rpm)		

电机配合方案 Motor Matching Scheme

Da	一级速比 One stage of gear ratio	二级速比 Second stage of gear ratio	三级速比 Third stage of gear ratio
	Φ14.25 ^{+0.05} _{-0.08}	5.36	-
Φ11.55 ^{+0.05} _{-0.08}	6.55	-	118.98
		28.05	145.36
Φ9.12 ^{+0.05} _{-0.08}	8.63	44.69	165.64
		58.22	191.56
		-	231.61
		-	301.68
		-	392.98
Φ21.45 ^{+0.05} _{-0.08}	3.65	13.53	67.08
		18.92	81.11
		24.65	91.36
		-	127.74

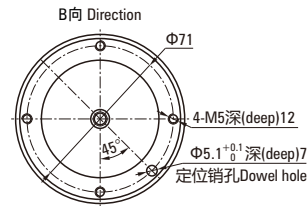
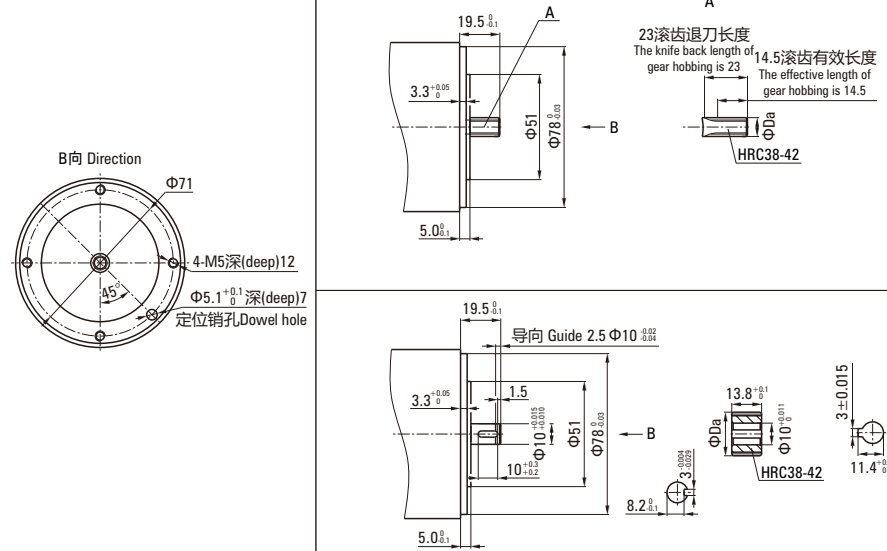

传动型行星 PLANETARY GEAR MOTOR

- 采用双支撑结构输出轴，使齿轮箱的承载扭力大大提高。

Adopt dual supporting structure for output shaft so that the max torque of gearbox is increased a lot.

- 太阳轮与行星架采用花键联接方式，极大增强了内部齿轮箱承受扭矩，提高了整机的使用寿命。

Sun wheel and planetary wheel are connected by spline which increase the max torque of gearbox and lengthen the life.

- 与电机连接的输入级采用斜齿，在高转速状态下，使齿轮箱的传动更加平稳，噪音更低。
- 齿轮箱内齿轮部分采用分段式结构，是齿轮箱的速比分布更广，整机结构设计更灵活。
- 齿轮箱与电机连接采用止口定位，轴向锁紧螺丝，使整机配合更精密，噪音更低。

• We use helical gear at input stage which make the noise low and run smoothly in high speed. • The inner gear ring is separated so that we can make more ratio and the design is flexible. • Gearbox and motor are located by a seam fix by screw in axial which increase the matching precision and reduce noise.

- 行星轮内孔采用滚针保持架，用滚动摩擦代替滑动摩擦，使齿轮箱的寿命更加长。

We use rolling pin holder inside planetary wheel. we use rolling friction instead of sliding grinding so the life of gearbox is much longer.

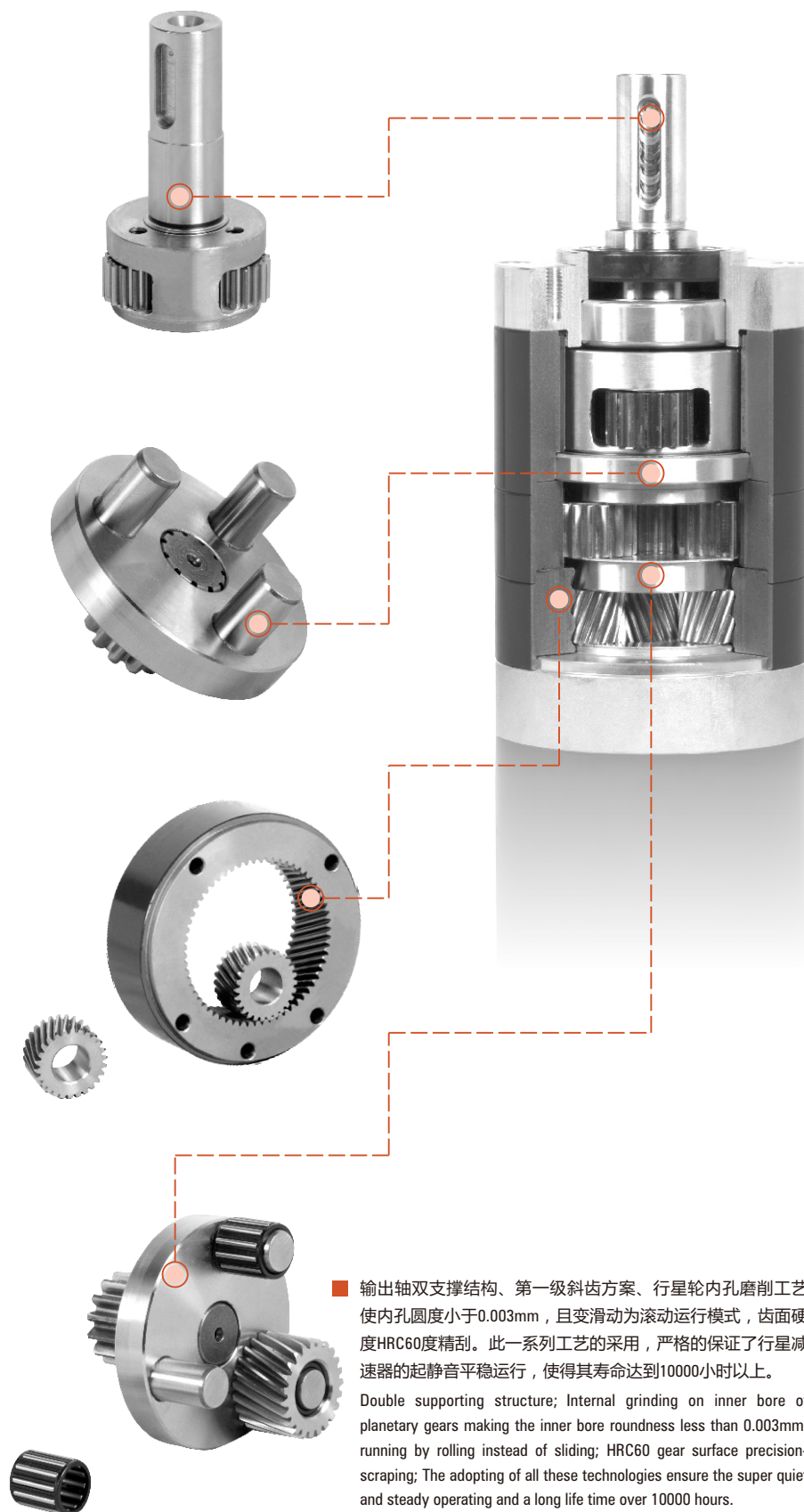

- 输出轴双支撑结构、第一级斜齿方案、行星轮内孔磨削工艺使内孔圆度小于0.003mm，且变滑动为滚动运行模式，齿面硬度HRC60度精刮。此一系列工艺的采用，严格的保证了行星减速器的起静音平稳运行，使得其寿命达到10000小时以上。

Double supporting structure; Internal grinding on inner bore of planetary gears making the inner bore roundness less than 0.003mm; running by rolling instead of sliding; HRC60 gear surface precision-scraping; The adopting of all these technologies ensure the super quiet and steady operating and a long life time over 10000 hours.

品名阅读方法 型番の説明 TYPE AND MOTOR NUMBER

モーター

电动机 Motor

Z 62 BLDPN 24 60 - 30S
 ① ② ③ ④ ⑤ ⑥

电动机参数 Motor Parameters モーターデータ	①	宁波中大力德智能传动股份有限公司标识 ZD Logo ZDのロゴ 电机外径尺寸 Motor Outline Dimension: モーター外径寸法 电机外径：モーター外径
	②	22:电机外径 Outer diameter Φ22mm 32:电机外径 Outer diameter Φ32mm 42:电机外径 Outer diameter Φ42mm 52:电机外径 Outer diameter Φ52mm 62:电机外径 Outer diameter Φ62mm 72:电机外径 Outer diameter Φ72mm 82:电机外径 Outer diameter Φ82mm 105:电机外径 Outer diameter Φ105mm 120:电机外径 Outer diameter Φ120mm
	③	电机型式 Motor Type: モータータイプ BLDPN:无刷直流电机, 配行星减速箱式 BLDC motor, matched with planetary gearbox BLDPN：ブラシレスDCモーター+遊星減速機 DPN:有刷直流电机, 配行星减速箱式 Brush DC motor, matched with planetary gearbox DPN：ブラシ付DCモーター+遊星減速機
	④	电机使用额定电压 Rated Voltage For The Motor Using 12:12V モーターの定格電圧 24:24V
	⑤	电机输出额定功率 Rated Output Power For The Motor 40:40W モーターの定格出力 60:60W
	⑥	电机输出额定转速 Rated Output Speed For The Motor 20S:2000RPM モーターの定格回転数 30S:3000RPM

減速機

减速机 Reducer

62 ZPN 303
 ① ② ③

①	减速机外径尺寸 Motor Outline Dimension: 減速機外径寸法 减速机外径：減速機外径 22:减速机外径 Gear box external diameter Φ22mm 32:减速机外径 Gear box external diameter Φ32mm 42:减速机外径 Gear box external diameter Φ42mm 52:减速机外径 Gear box external diameter Φ52mm 62:减速机外径 Gear box external diameter Φ62mm 72:减速机外径 Gear box external diameter Φ72mm 82:减速机外径 Gear box external diameter Φ82mm 105:减速机外径 Gear box external diameter Φ105mm 120:减速机外径 Gear box external diameter Φ120mm
②	类型 Motor Outline Dimension: タイプ ZPN:减速机输入斜齿轮 Gear box input shaft is helical gear ZPN減速機入力はヘリカルギア
③	减速比 Gear Ratio: 減速比 例.303:減速比 Reduction ratio:303:1 例えば、303は減速比が303:1